

OACIS

Open Architecture Control Integrated System

Installation Instruction for OACIS-1X

Version 01.13



www.atainc.com

ata@atainc.com

All Rights Reserved



CONTENTS

I. SAFETY INSTRUCTIONS.....	4
II. OACIS OVERVIEW	6
A. Part Names	6
B. Exterior Dimensions	7
III. OACIS POWER IN and GROUND CONNECTIONS	8
A. Circuit Diagram	8
B. Wiring Example	8
IV. DIGITAL INPUT CONNECTIONS	9
A. Circuit Diagram	9
B. Wiring Example	10
V. DIGITAL OUTPUT CONNECTIONS	12
A. Circuit Diagram	12
B. Wiring Example	12
VI. ANALOG INPUT CONNECTIONS: IOCN3 / TB#1	14
A. Circuit Diagram	14
B. Wiring Example	15
VII. SERVO CONNECTIONS.....	17
A. Wiring Example	17
VIII. JUMPER and SELECTION S/W SETTING.....	20
A. Jumper Settings	20
B. Selection S/W Settings	22
IX. CABLE CONNECTIONS.....	25
A. RS232 Port.....	25
B. Encoder Input Port (Line Driver)	26
C. Encoder Input Port (TTL, Open Collector)	27
X. ESTOP CIRCUIT	28
A. ESTOP Circuit Diagram	28
B. Wiring Example	28
C. Precautions for Wiring.....	29
XI. POWER DISSIPATION SPECIFICATIONS	30
A. OACIS-1X : 10 W	30
B. PANASONIC A5 MOTOR DRIVERS	30
REVISION	31

WARRANTY



ATA's exclusive warranty is one year from date of sale by ATA.

ATA shall not be responsible for warranty, repair or other claims regarding the products that are not properly handled, stored, installed, operated and maintained per ATA's instructions.

I. SAFETY INSTRUCTIONS

Do not install, operate or maintain the OACIS until you have read through this installation manual and related servo drive manuals.

In this manual, the safety levels are classified into “WARNING” and “CAUTION” as below.

 WARNING	<p>Indicates that incorrect handling may cause hazardous conditions resulting in death or severe injury.</p>
 CAUTION	<p>Indicates that incorrect handling may cause hazardous conditions resulting in slight injury to personnel or may cause physical damage to the OACIS.</p>



WARNING

1. Before wiring or inspection, power off and wait for longer than 5 minutes. And confirm if the voltage level is safe enough. Otherwise, you may get an electric shock.
2. The person who is working for the OACIS especially to wire, inspect and operate, should be fully competent to do the work.
3. Operate the Power In with dry hand. Otherwise, you may get an electric shock.
4. The Cables should not be damaged, stressed or loaded to prevent electric shock.
5. With all covers closed, do Power-On or Operation to prevent electric shock.
6. Except for Jumper Setting, do not remove any covers. Otherwise, you may get an electric shock.
7. Ensure the polarity (+, -) is correct. Otherwise, a burst or damage may occur.
8. Connect Frame GND correctly to prevent severe damage.
9. Do not connect Power In to IOCN3 terminal block. It causes severe damage.

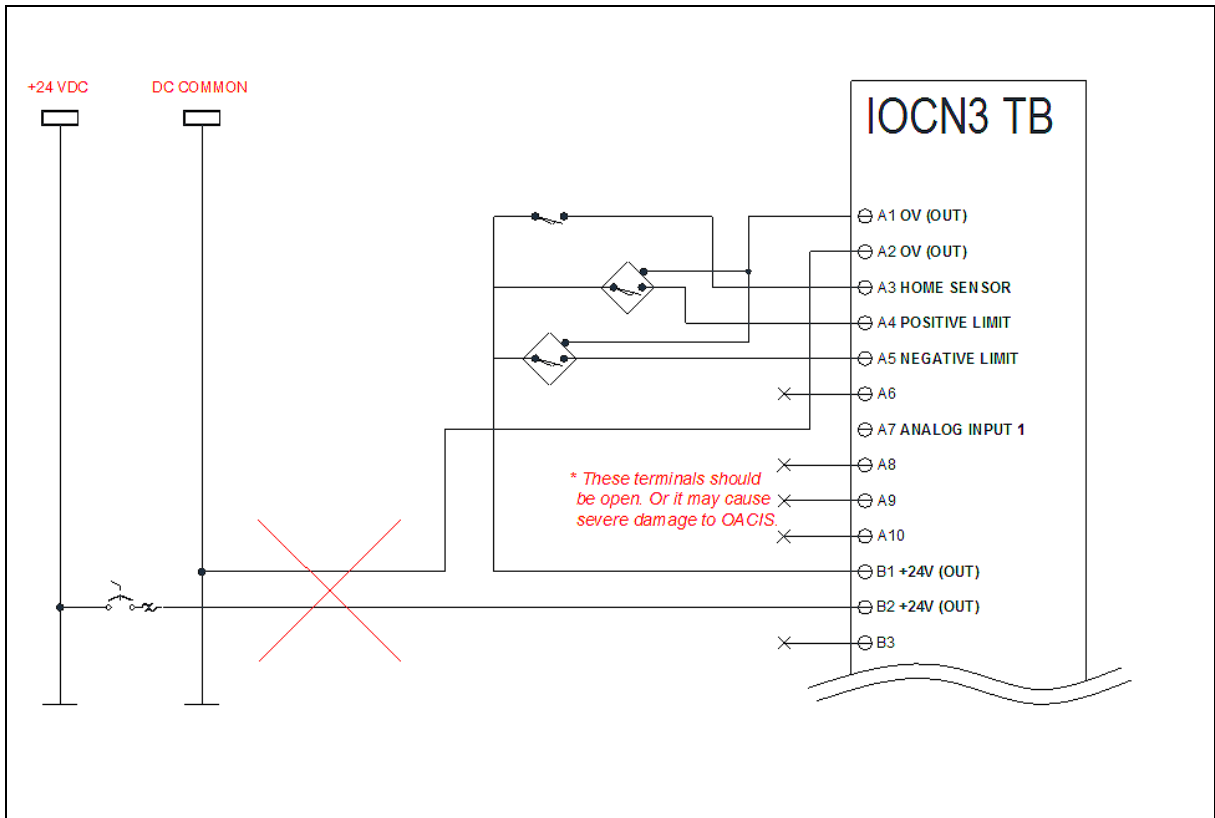

CAUTION

1. Ensure the proper setting in accordance with external device signal type. Otherwise, a burst or damage may occur.
2. Connect the terminals correctly to prevent a burst or damage.
3. Proper Circuit Breaker is to be installed before Power In to prevent damage.
4. Install the OACIS a load-bearing place.
5. Do not put heavy objects on the OACIS.
6. Use the proper cable between OACIS and Servo Drive ATA provided.
7. Leave specified clearances between the OACIS and enclosure walls.
8. Do not drop or impact the OACIS.
9. Environmental Conditions

	MIN	MAX
Ambient Temperature for Operation	-10 °C	+60 °C
Ambient Temperature for Storage	-20 °C	+70 °C
Ambient Humidity	--	90%RH
Ambience	Free from corrosive gas, flammable gas, oil mist, dust and dirt	

II. OACIS OVERVIEW

A. Part Names

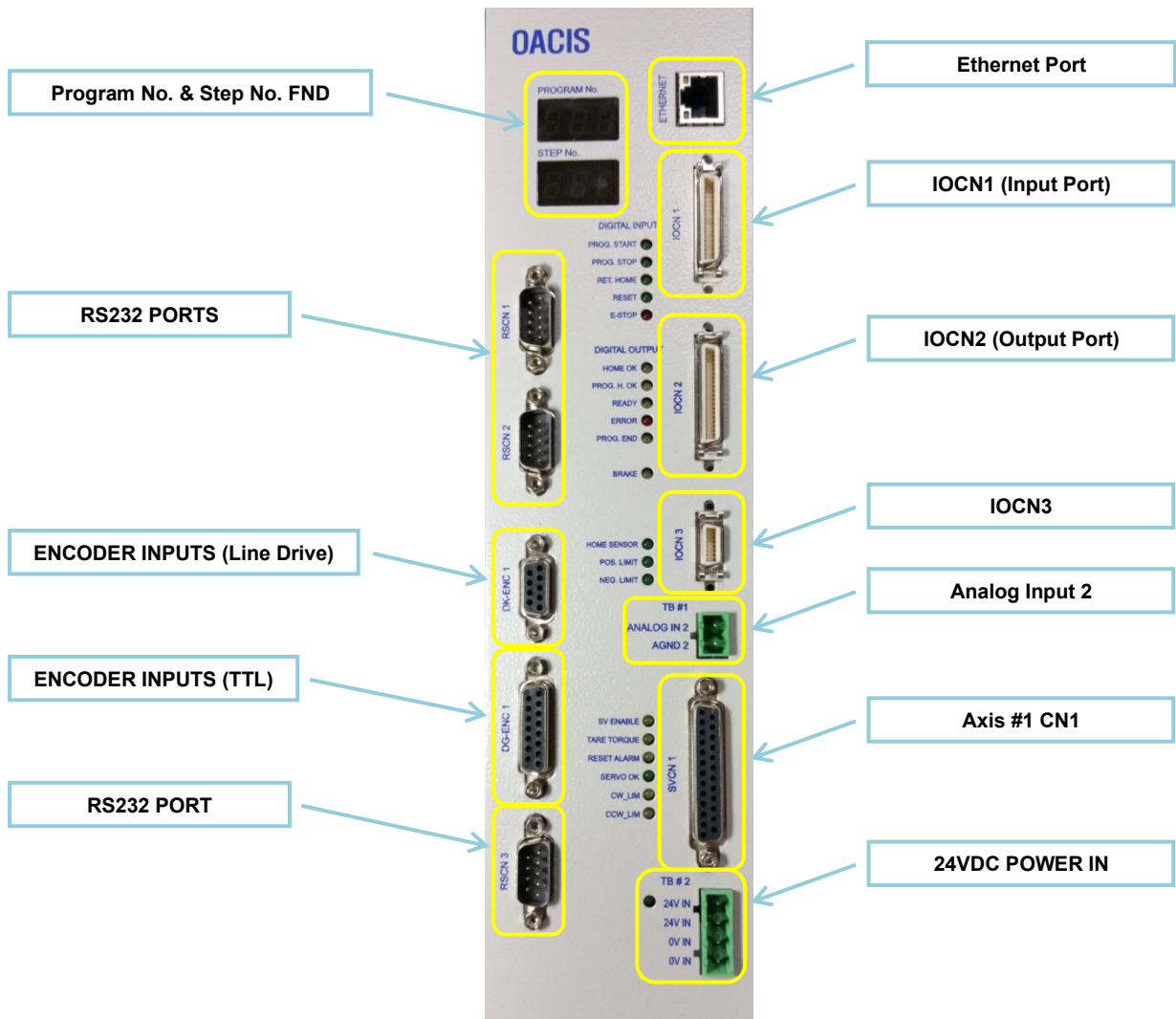

- Ethernet Port: RJ45
- RS232 Port: DSUB 9pin
- AXIS #1: DSUB 25pin
- Encoder Input: DSUB 9pin(TTL) / DSUB 15pin(Line Drive)

B. Exterior Dimensions

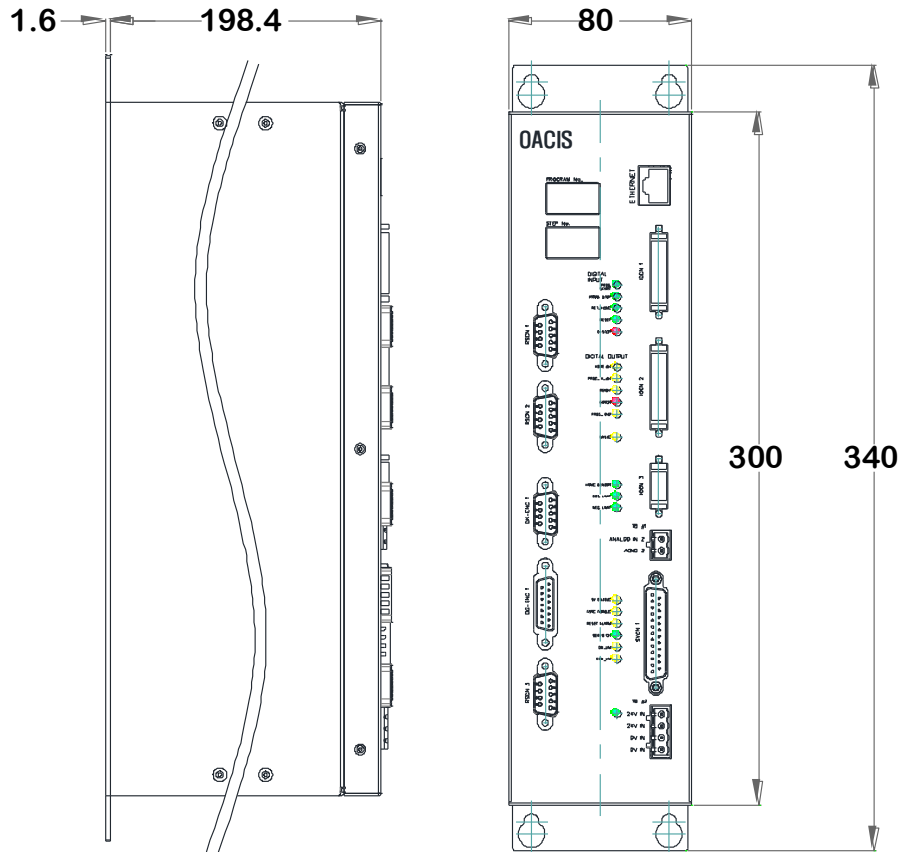

INSTALLATION AND
MAINTENANCE
INSTRUCTION

< MOUNTING DIMENSIONS >

< BOTTOM VIEW >

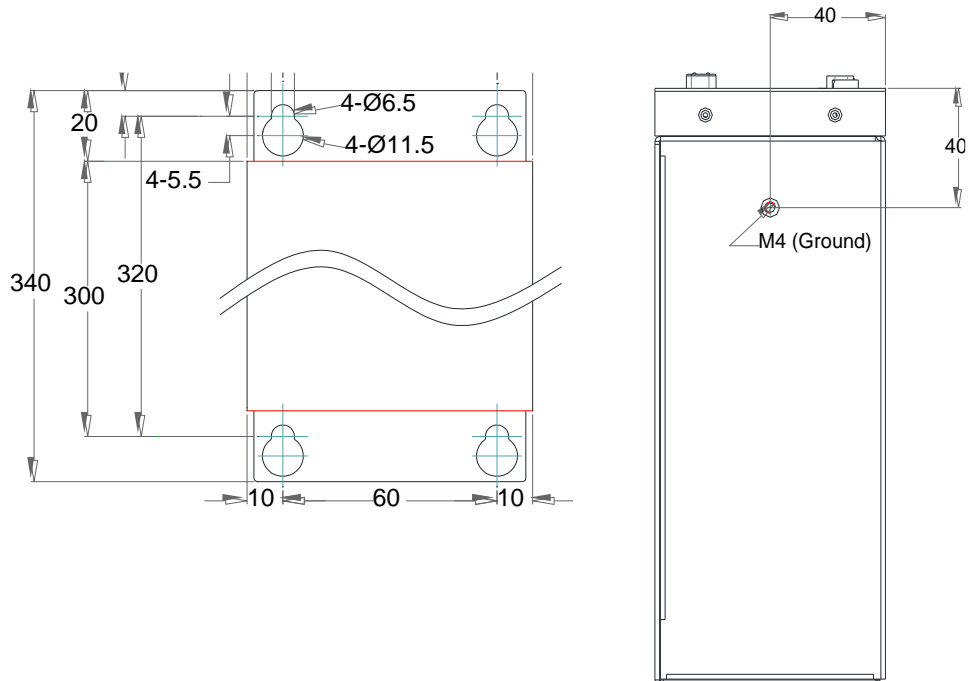

III. OACIS POWER IN and GROUND CONNECTIONS

: TB#2

A. Circuit Diagram

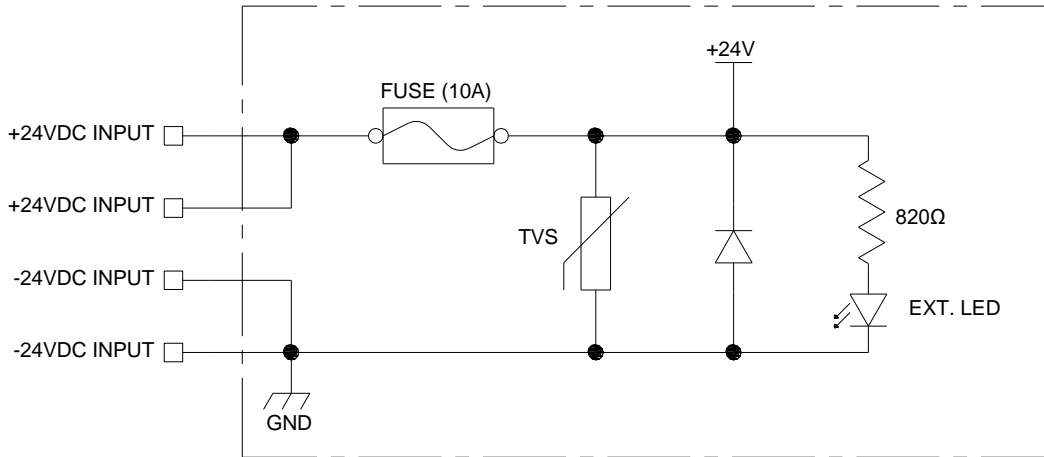

B. Wiring Example

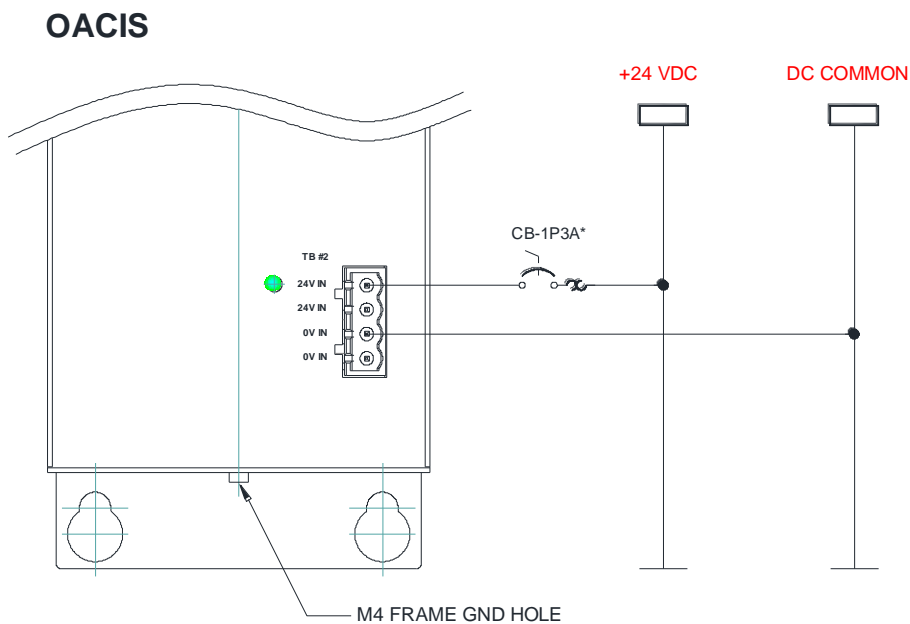

- It is recommended to use a proper Circuit Breaker per the application.
- OACIS itself requires minimum 0.6A (without any connections). It requires more current consumption depending on the application.
- It is recommended to separate Power-In Connection from frequent Turn On and Off circuit like Light Curtain.

IV. DIGITAL INPUT CONNECTIONS

: IOC1

A. Circuit Diagram

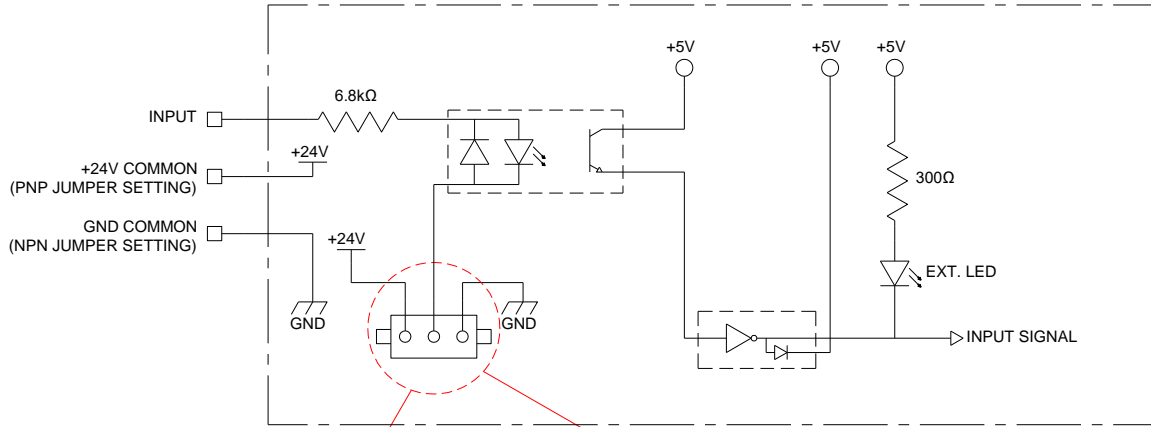

< NPN TYPE INPUT JUMPER SETTING >

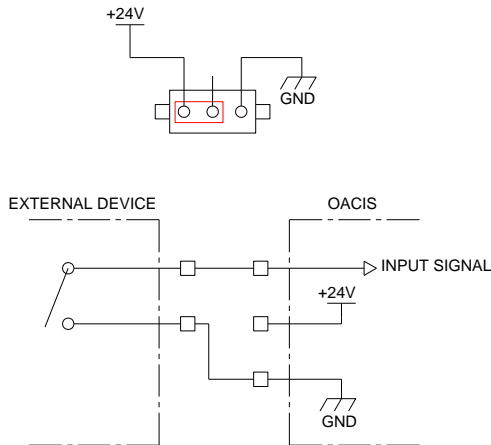

< PNP TYPE INPUT JUMPER SETTING >

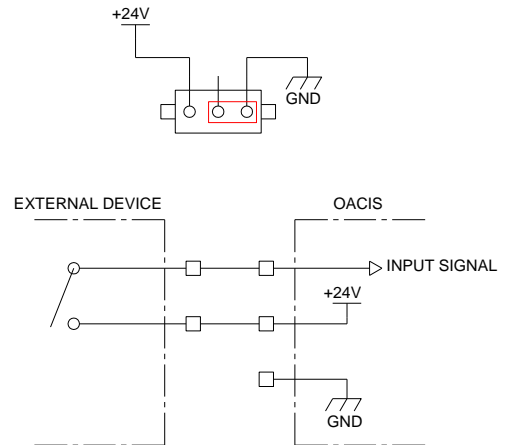

- See the “Chapter VIII” regarding how to set PNP or NPN.
- Min. 3.5mA @24VDC is required to switch each channel.
- ⚠ Min. 20VDC is required.
- ⚠ Max. 30VDC is allowed.
- ⚠ Over voltage input may cause severe damage to OACIS.

B. Wiring Example

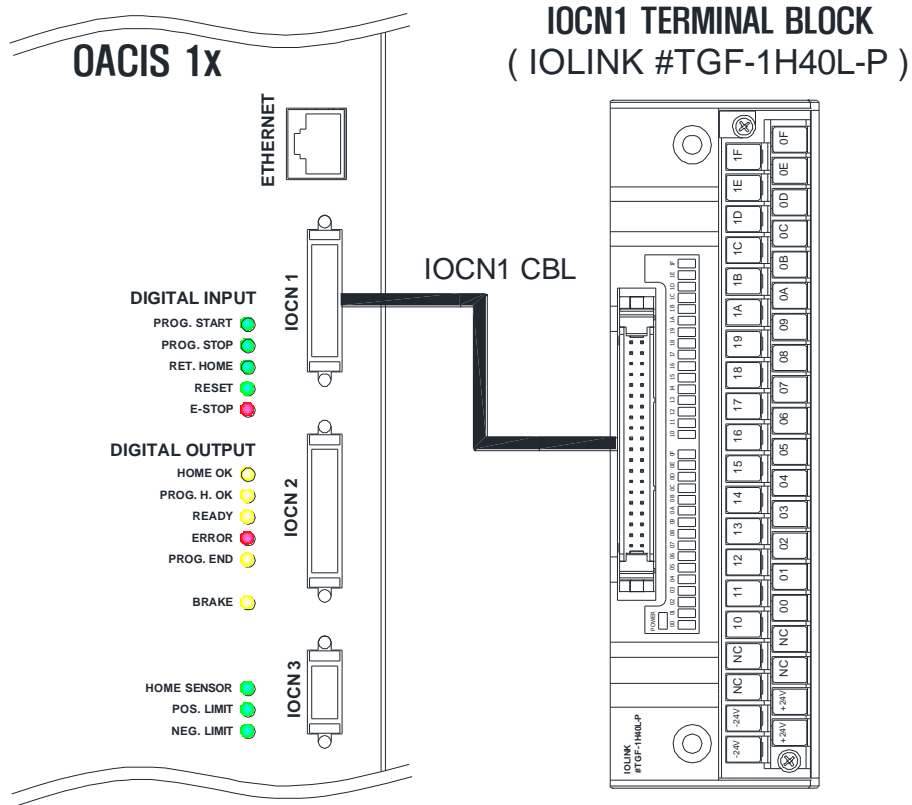

- This wiring example is for PNP type.
- "24V" channel of IOCN1 Terminal Block is "Input". Connect the same 24V Power Input to this channel as OACIS 24V Power In. Or it may cause improper operations of OACIS.
- IOCN1 terminal block for PNP is TGF-1H40L-P and one for NPN is TGF-1H40L-N.

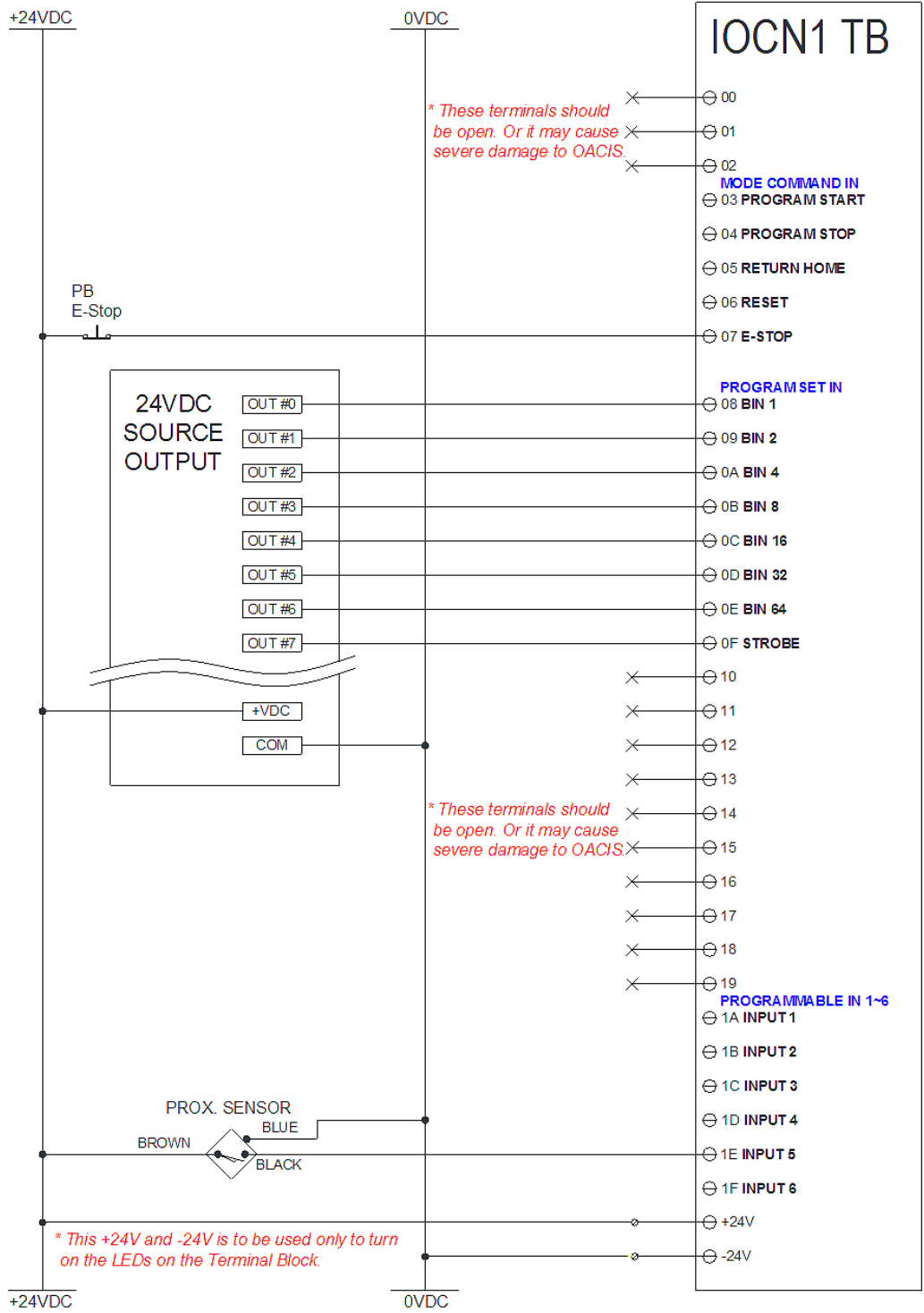

V. DIGITAL OUTPUT CONNECTIONS

: IOCN2

A. Circuit Diagram

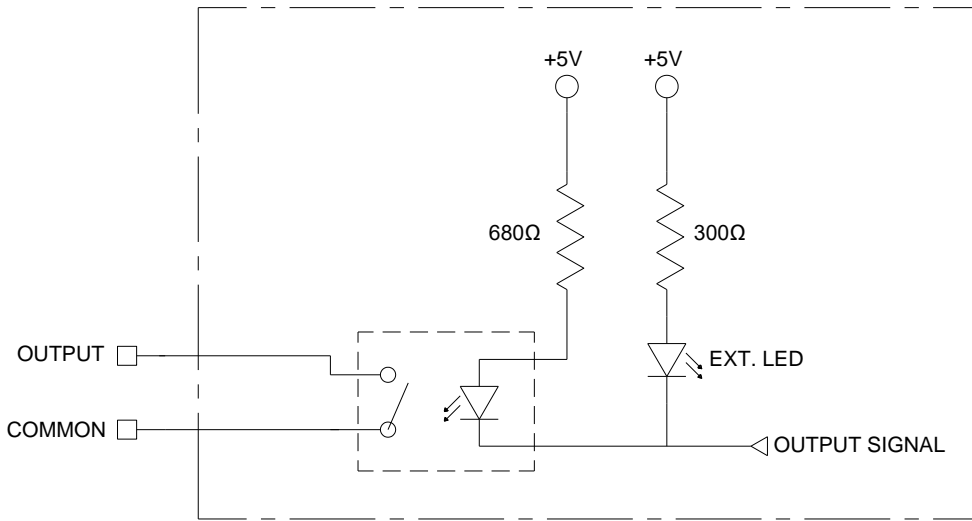

- OACIS provides “TR” type Digital Output Channel.
- Max Allowable Voltage between ‘OUTPUT’ and ‘COMMON’: 30V
- Max Allowable Current between ‘OUTPUT’ and ‘COMMON’: 300mA
- ⚠ Over voltage input may cause severe damage to OACIS.

B. Wiring Example

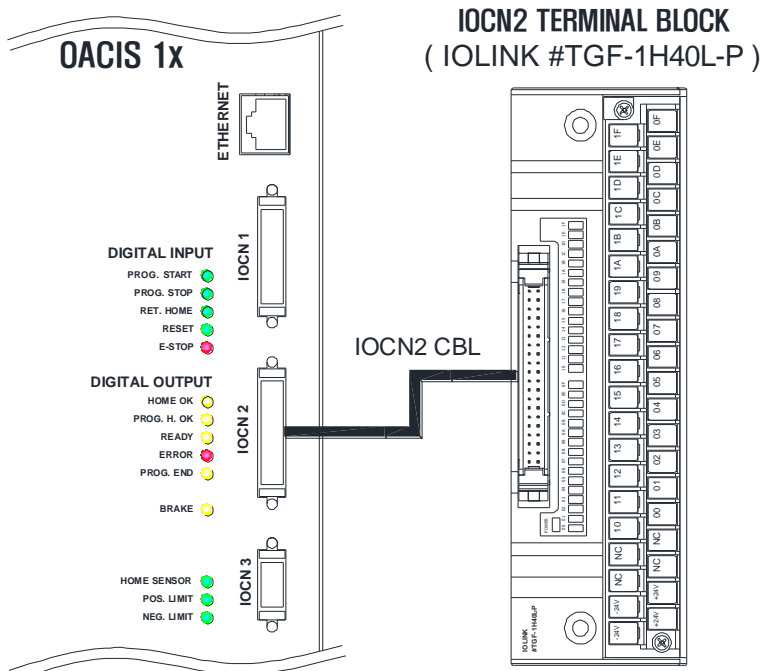

- ⚠ “24V” channel of IOCN2 Terminal Block is “Input”. Connect the same 24V Power Input to this channel as OACIS 24V Power In. Or it may cause improper operations of OACIS.
- IOCN2 is composed of 4 DO Terminal Blocks such as MODE STATUS OUT, BRAKE, PROGRAM SET OUT and PROGRAMMABLE OUT.
- Each DO Terminal Block has its own Common Terminal that is “24VDC or 0VDC Input” per PNP/NPN.

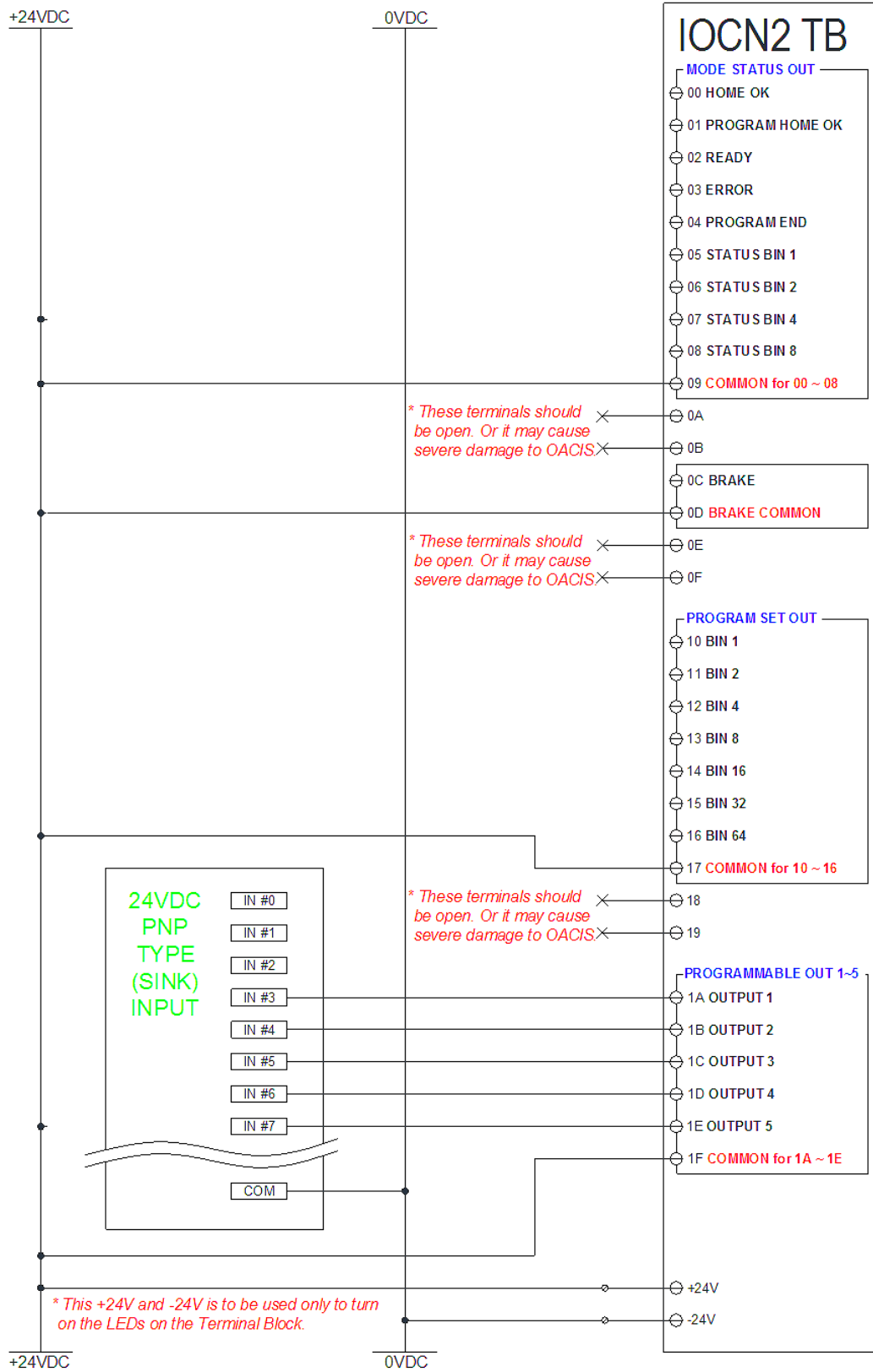

VI. ANALOG INPUT CONNECTIONS: IOCN3 / TB#1

A. Circuit Diagram

INSTALLATION AND
MAINTENANCE
INSTRUCTION

● CURRENT type Input Setting

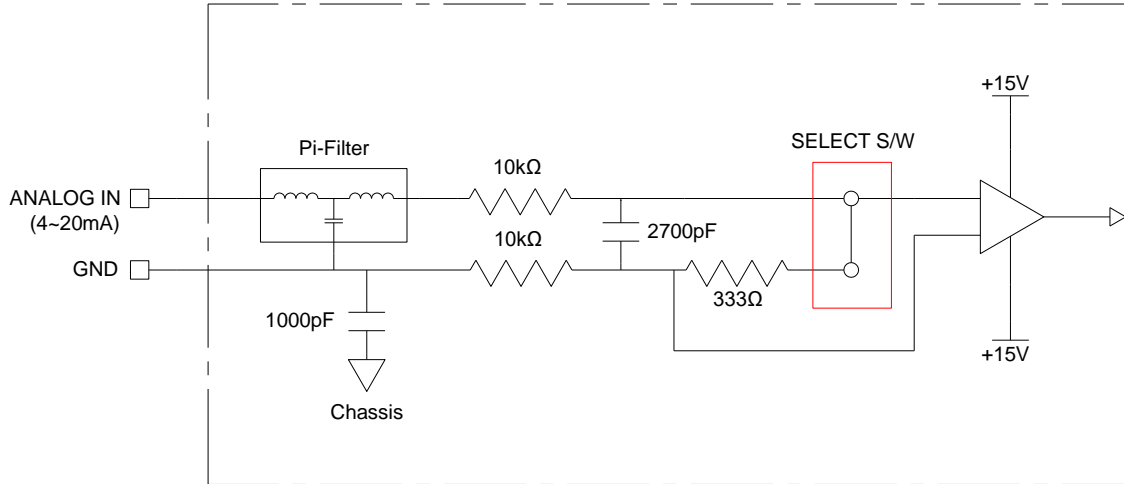

● VOLTAGE type Input Setting

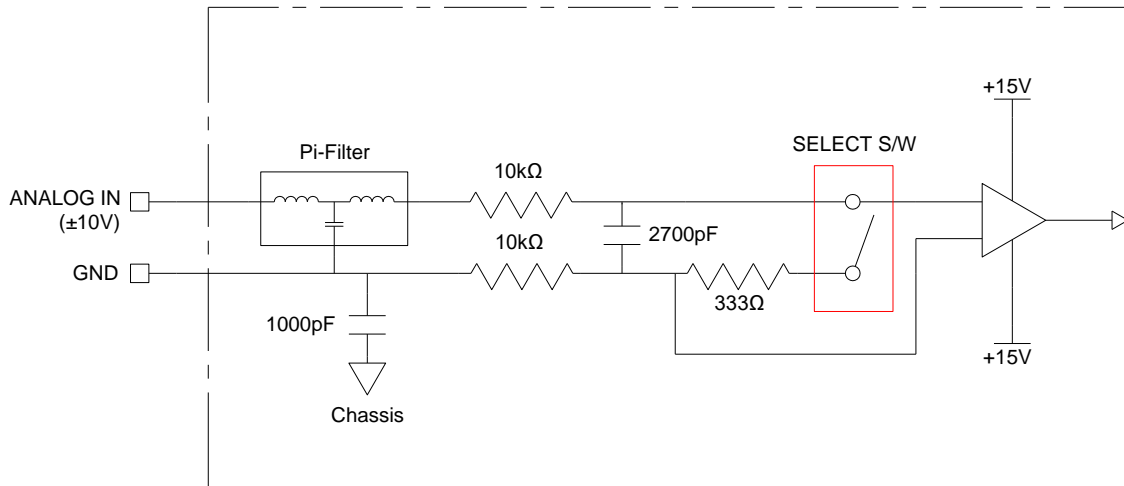

B. Wiring Example

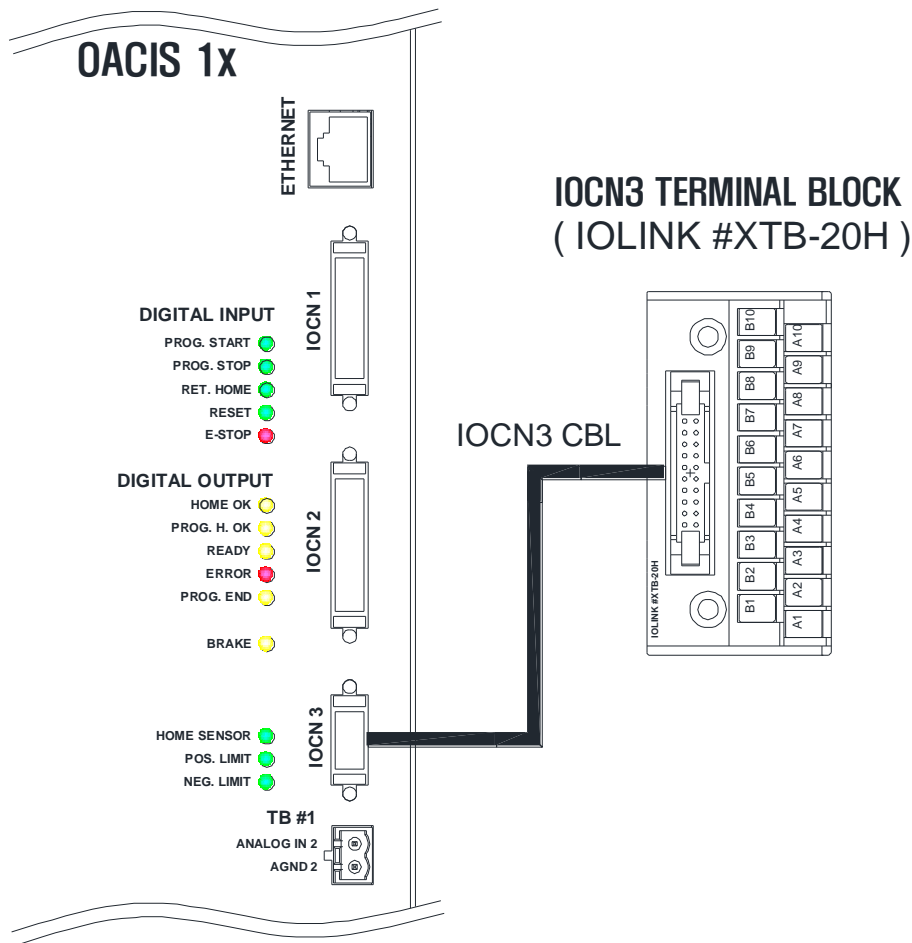

INSTALLATION AND MAINTENANCE INSTRUCTION

- Each Analog Input Channel has its own GND terminal.
- Each Analog Input Channel is reading the signal as differential mode.
- Signal Type Selection Switch needs to be set properly per the input signal type.
 - See the “Chapter VIII” regarding how to set AI signal type.
- Allowable Signal Range:
 - With Voltage Input Setting: -15V ~ +15V
 - With Current Input Setting: -30mA ~ +30mA
 - ⚠ OACIS is cutting off the overflowed signal (+/-10V or 4~20mA).
 - ⚠ Over current or voltage input may cause severe damage to OACIS.
 - ⚠ It should be wired to the OACIS Analog Input Channel directly not through any other Terminal Blocks.
 - ⚠ The power cable and AMP cable should be separated each other. And shield wires in AMP signal cables should be connected to IOC3 Frame GND (A6 or B6) directly to reduce noise levels.

THERE ARE TWO KINDS OF HOME SENSORS PROVIDED BY ATA DEPENDING ON SERVO PRESS MODEL. ONE HAS 3 WIRES AND THE OTHER ONE HAS 2 WIRES. IN THE CASE OF 2 WIRES, BROWN IS 24VDC AND BLUE IS SIGNAL. IN THE CASE OF 3 WIRES, BROWN IS 24VDC, BLUE IS 0VDC AND BLACK IS SIGNAL. PLEASE CONFIRM THE WIRING BEFORE POWER ON. OTHERWISE, THE SENSOR WOULD BE DAMAGED. THIS EXAMPLE SHOWS 2-WIRE TYPE HOME SENSOR.

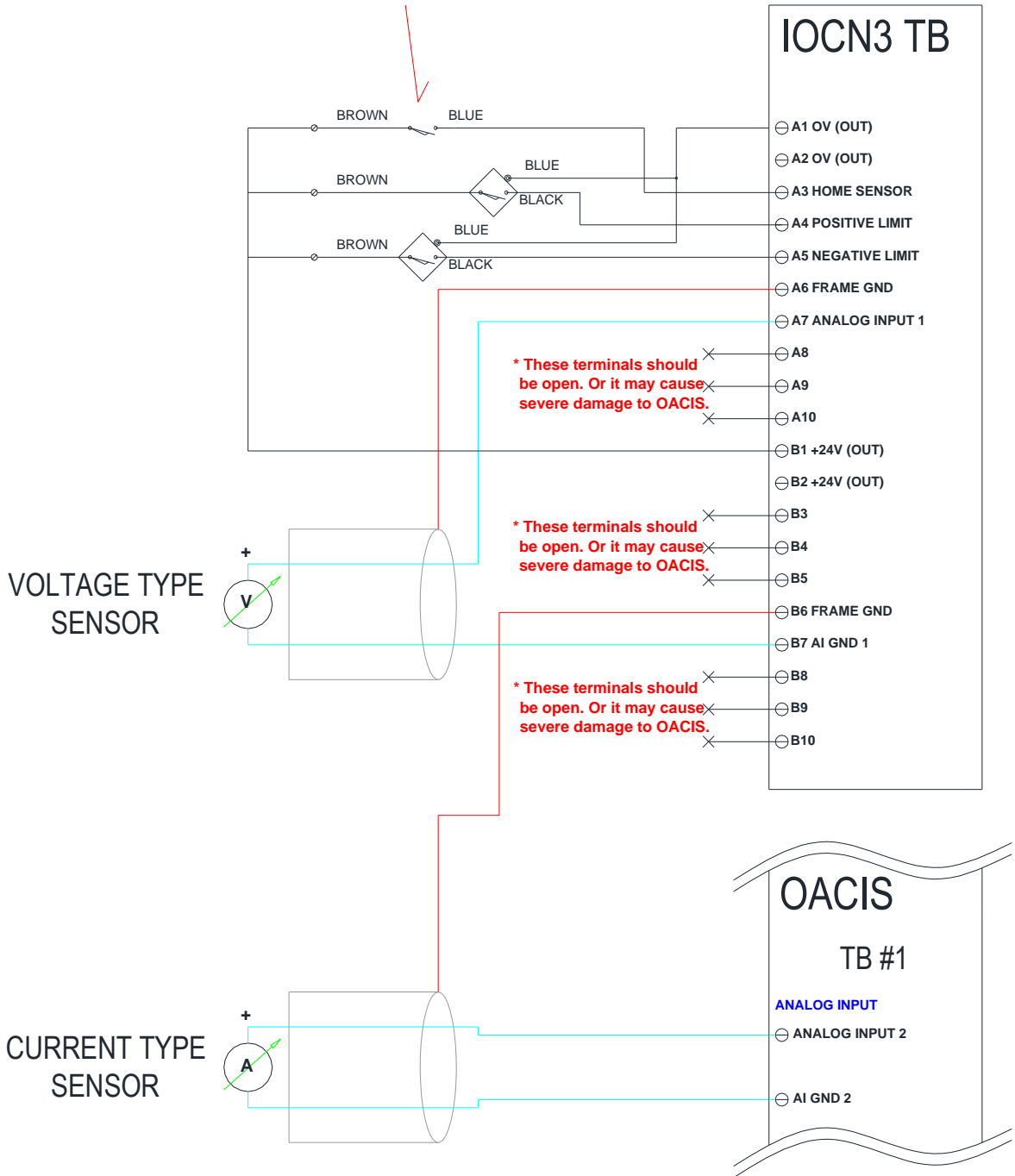

VII. SERVO CONNECTIONS

A. Wiring Example

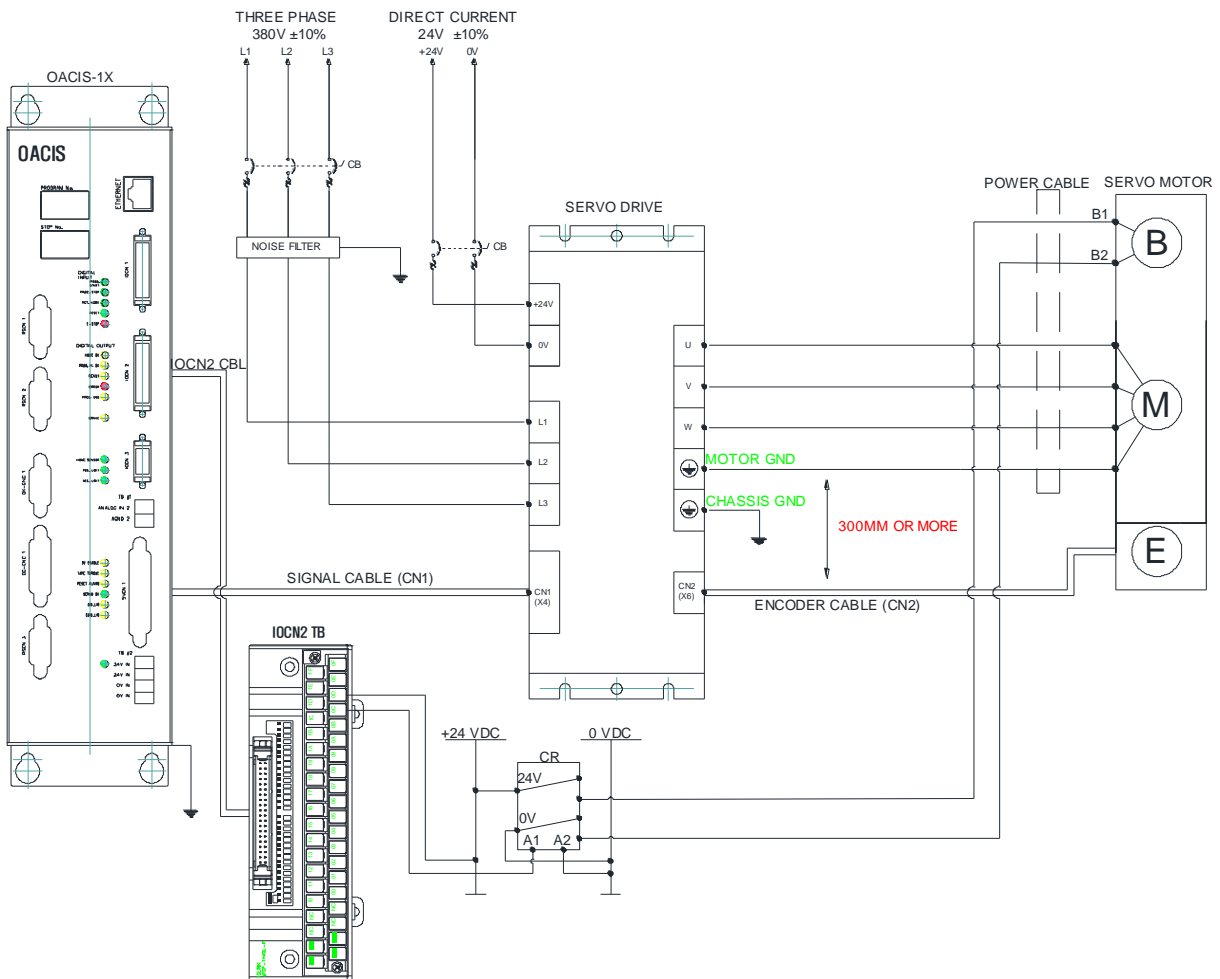

- This wiring example is reference only.
- ⚠ **Max Allowable Voltage between 'BRAKE' and 'COMMON': 30V**
- ⚠ **Max Allowable Current between 'BRAKE' and 'COMMON': 300mA**
- Different Servo Motor requires different circuit. (Consult ata@atainc.com)
- You can find detailed wiring example at the www.atainc.com
- PANASONIC A5 Servo is default for OACIS.
- OMRON, LS and Mitsubishi servo system is an option.
- ⚠ **If the noise signal levels are high due to the unexpected electric interference, it can work to clamp a ferrite with U, V and W wires together.**
- In case of installing external regenerative resistors to a servo drive for P200 servo presses, please refer to wiring example

- In case of 3-phase, 400V, G-frame type for P200 servo presses

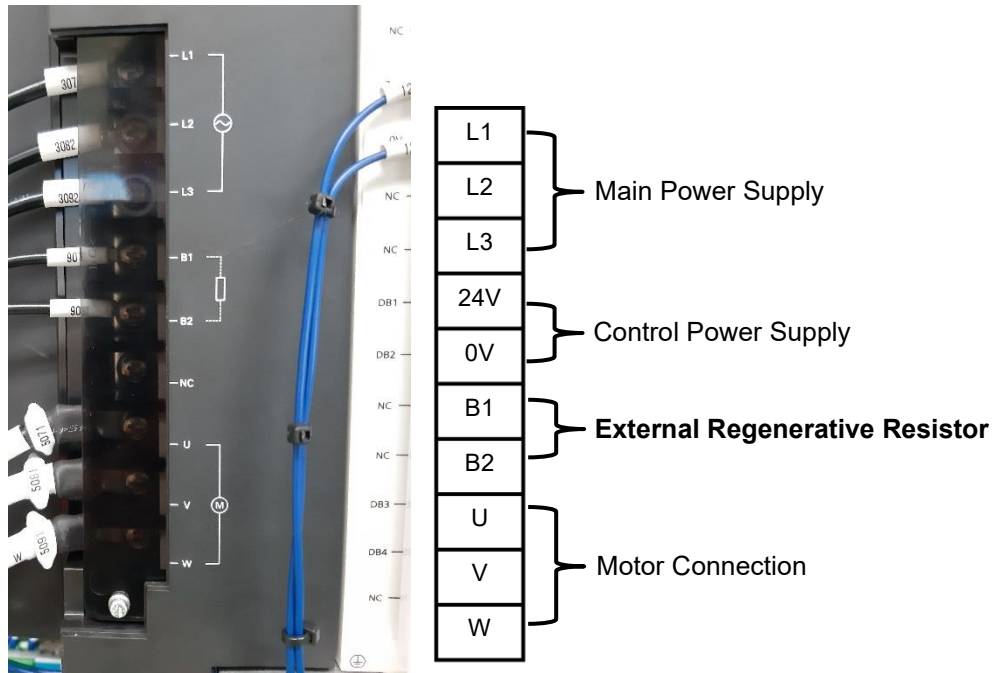

Recommended regenerative resistor

Frame	Power Supply	
	3 phase, 200V	3 phase, 400V
G	DV0P4285 X 3 in Parallel	DV0PM20049 X 3 in Parallel

Part No.	Specifications				
	Resistance	Cable outside diameter	Weight	Rated power (reference)	
				Free air	With Fan
Ω	mm	kg	W	W	
DV0P4285	20	ϕ 1.27 AWG18	1.2	52	130
DV0PM20059	80	stranded wire	1.2	65	190

- ⚠ **Regenerative resistors get very hot. Install a cooling fan according to the worst running conditions.**
- ⚠ **Avoid the installation near easily accessible place by hand.**
- ⚠ **Install them away from inflammable objects and take preventive measures for fire and burns.**

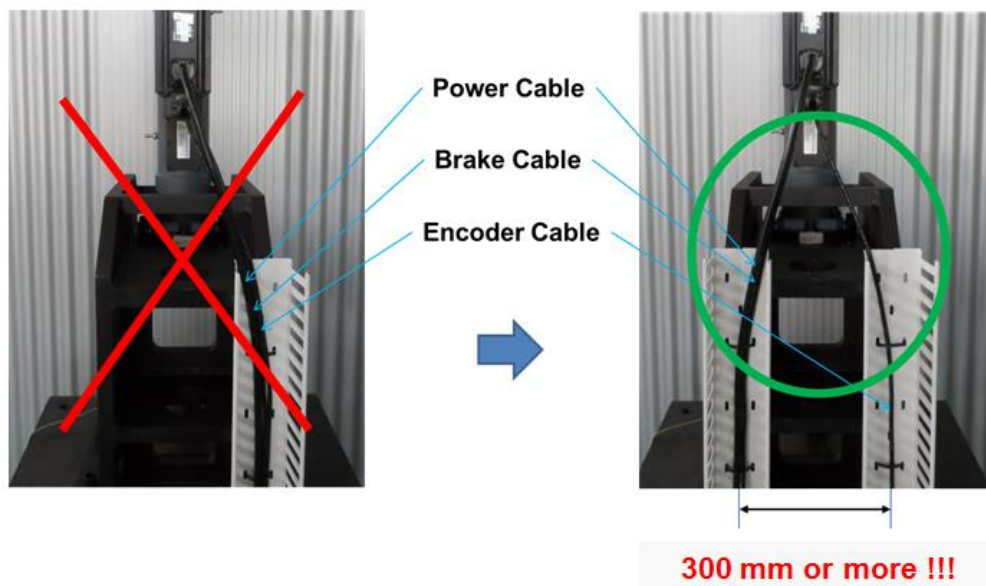
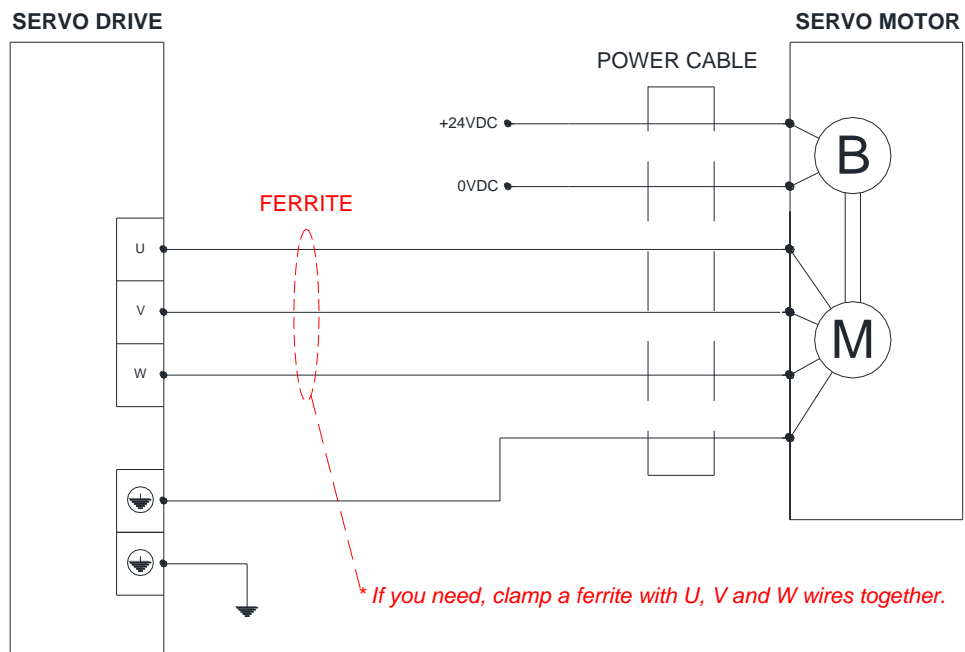

- ⚠ Keep the encoder cable away from the power cable wiring by 30 cm or more. Do not guide the encoder cable through the same duct as the power cable, nor bind them together.
- There are two ground terminals provided on the driver. One of them must be connected to the ground terminal of the control panel and the other is for the motor ground.
- ⚠ The ground terminal must not be shared with other equipment.
- ⚠ Overall pay particular attention to miswiring especially in power input and motor output, ground or loose connection.
- Contact ATAinc for more details.

VIII. JUMPER and SELECTION S/W SETTING

A. Jumper Settings

INSTALLATION AND MAINTENANCE

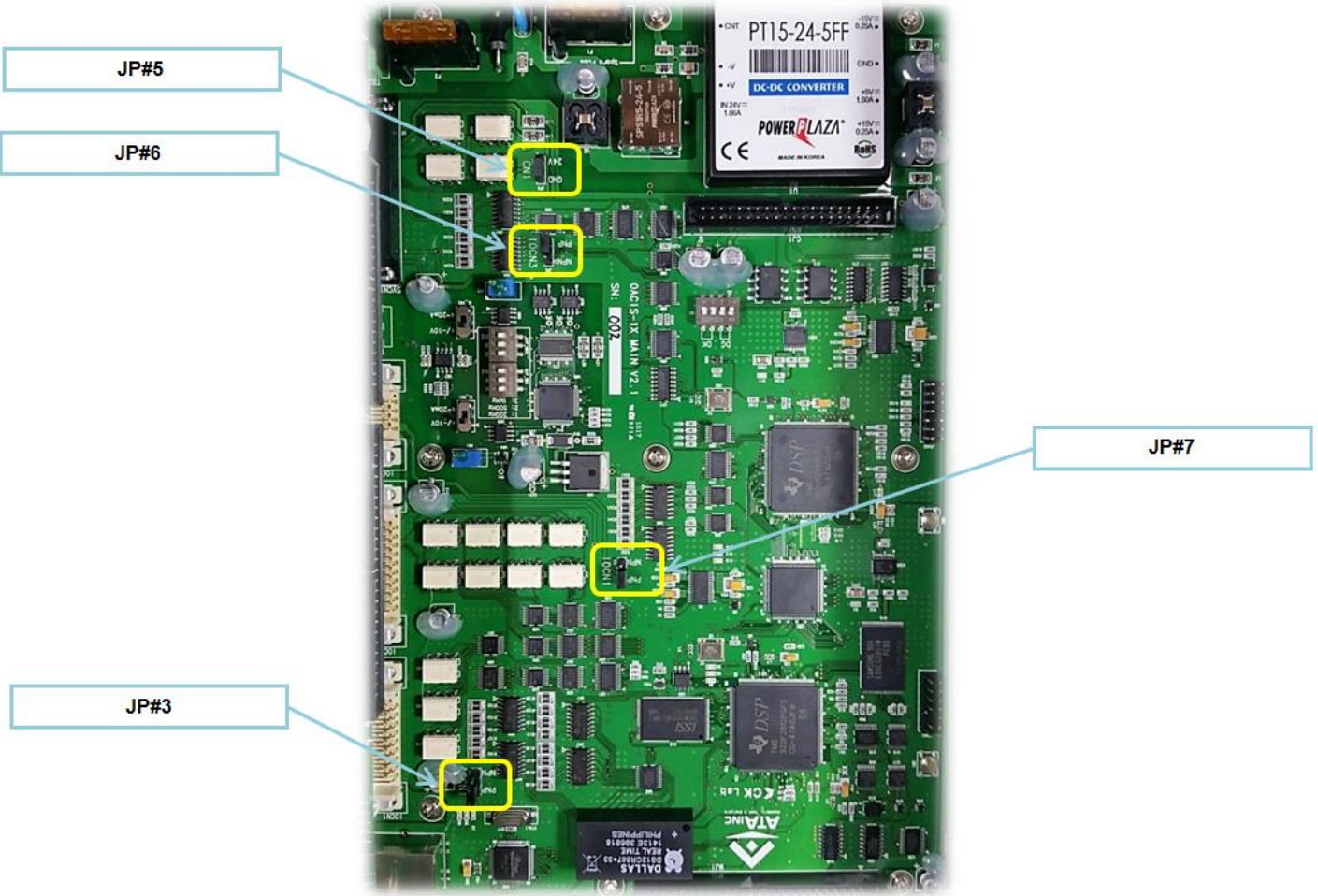

- **JP#3: Program Set In & Mode Command In (IOCN1) Digital Input Signal Type**
 - One Jumper is to be used to set all Program Set In and Mode Command In Channels.

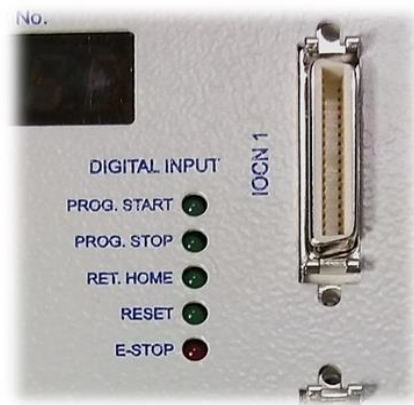

- **JP#7: Programmable DI (IOCN1) Digital Input Signal Type**
 - One Jumper is to be used to set all Programmable DI Channels

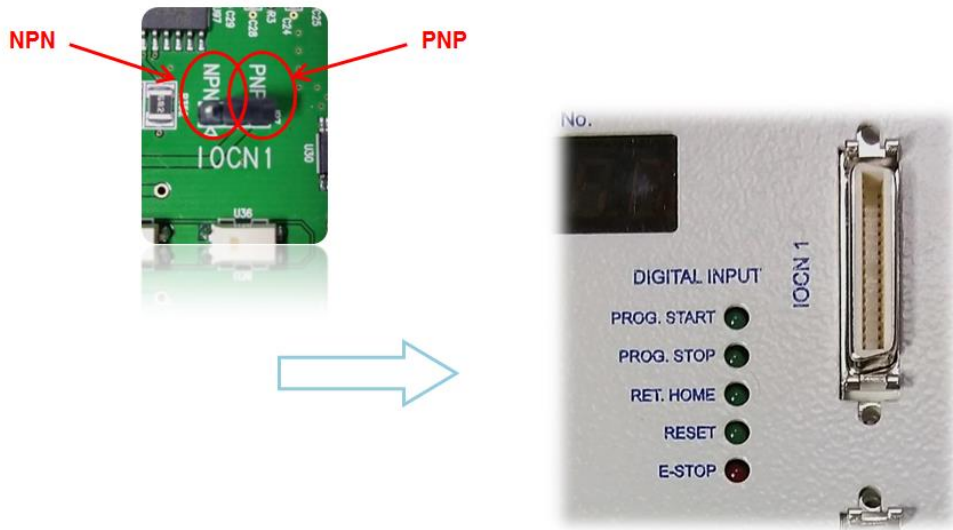

INSTALLATION AND MAINTENANCE INSTRUCTION

- **JP#5: AXIS1 CN1 Cable DI/O Signal Type**
 - It is to be used to set DI/O signal type in CN1 Cable. If the servo drive is using PNP type signal, it should be set as "24V" else if the signal is NPN, it should be "GND".
 - Default OACIS DI in CN1 is set as NPN (SINK).

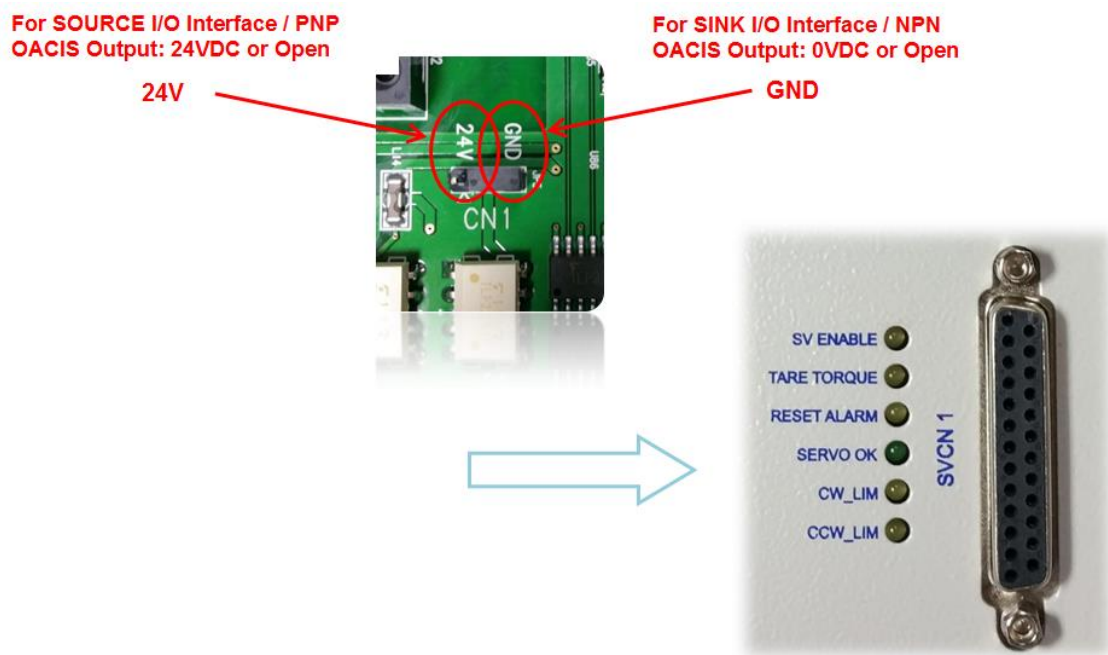

- **JP#6: AXIS1 (IOCN3) Home, Positive Limit and Negative Limit Sensors Signal Type**
 - One Jumper is to be used to set all Channels.

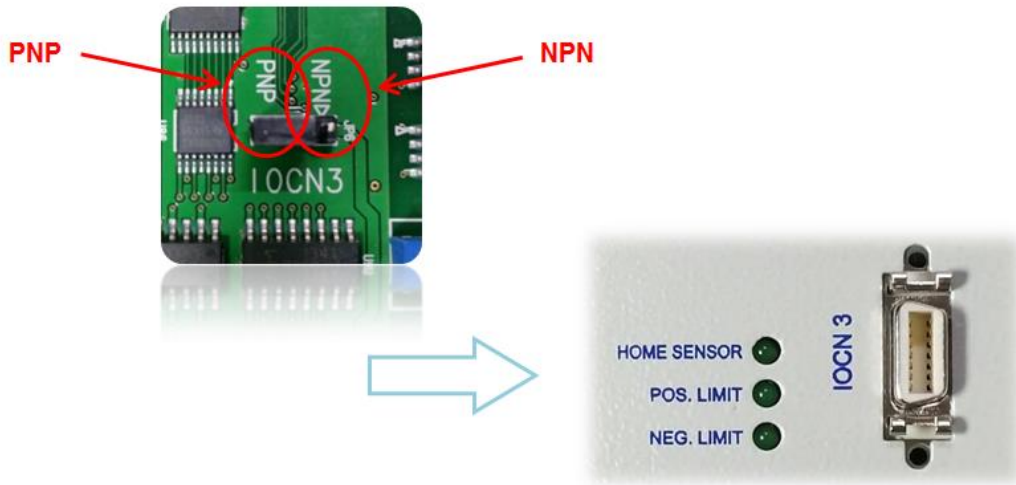

B. Selection S/W Settings

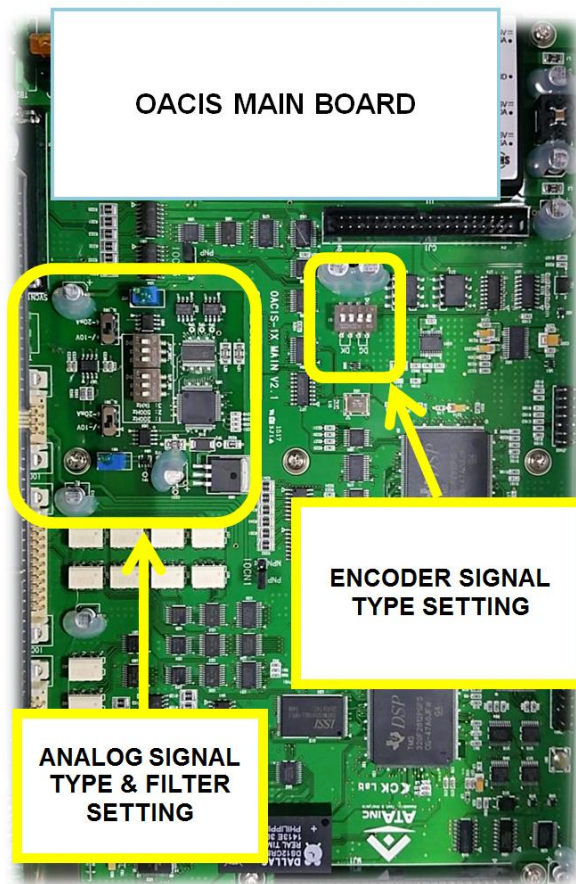

- Analog Input Signal Type & Filter Settings

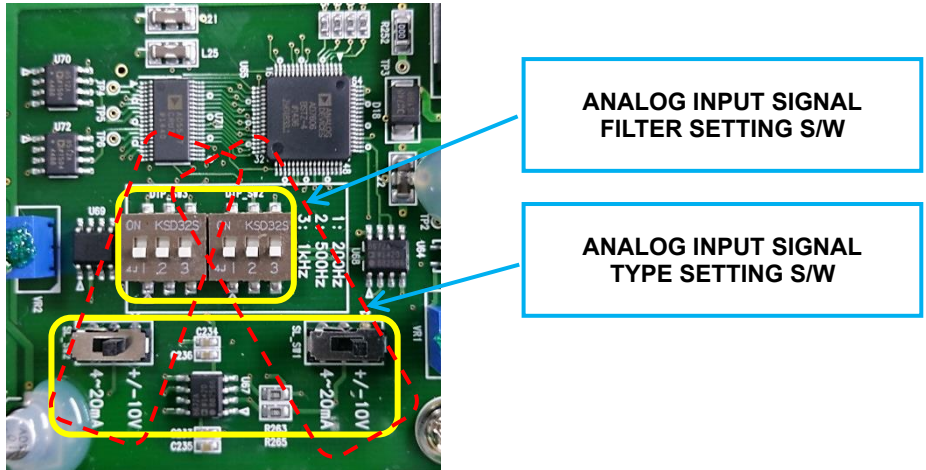

- Analog Signal Filter Dip Switch Setting

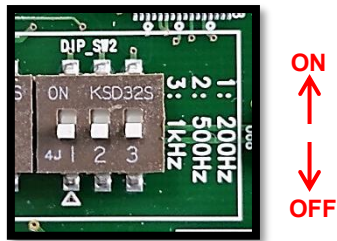

- S/W #1: 200Hz (Default: Off)
- S/W #2: 500Hz (Default: Off)
- S/W #3: 1kHz (Default: Off)

- Analog Signal Type Selection Switch Setting

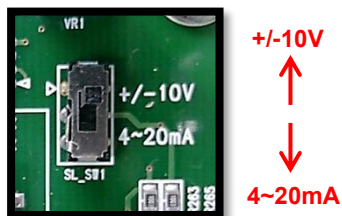

- Default Setting: +/-10V

● ENCODER Signal type Setting

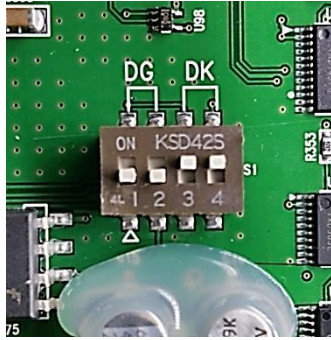

ON
↑
↓
OFF

➤ Encoder Input Channel #1 Setting

DP#	STATUS	SIGNAL TYPE
1	ON	TTL (DG Channel)
2	ON	
3	OFF	
4	OFF	
1	OFF	LINE DRIVE (default) (DK Channel)
2	OFF	
3	ON	
4	ON	

IX. CABLE CONNECTIONS

A. RS232 Port

- Port Type: DSUB 9pin Male Connector

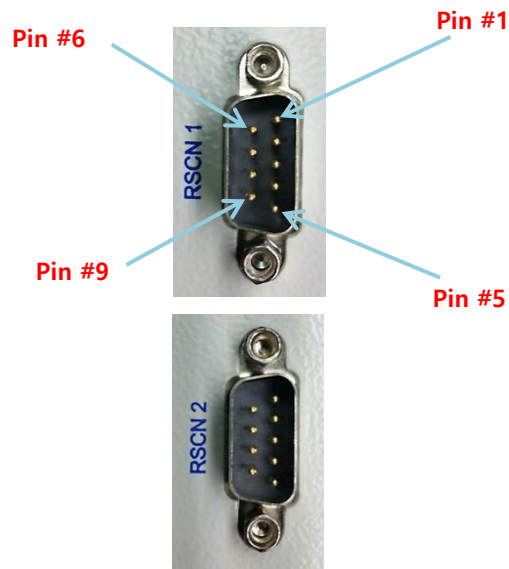

- Pin Assignment

PIN No.	PIN ASSIGNMENT	PIN No.	PIN ASSIGNMENT
1	No Connection	6	No Connection
2	RXD (OACIS IN)	7	No Connection
3	TXD (OACIS OUT)	8	No Connection
4	No Connection	9	Shield
5	GND		

⚠ Only Pin #2, #3 and #5 need to be connected properly. Connection of other pins(#1, #4, #6, #7 and #8) is not allowed.

B. Encoder Input Port (Line Driver)

- This port is for A/B/Z Phase Voltage Differential Line Driver Output.
- Compliant with RS-422
- Port Type: DSUB 9pin Female Connector

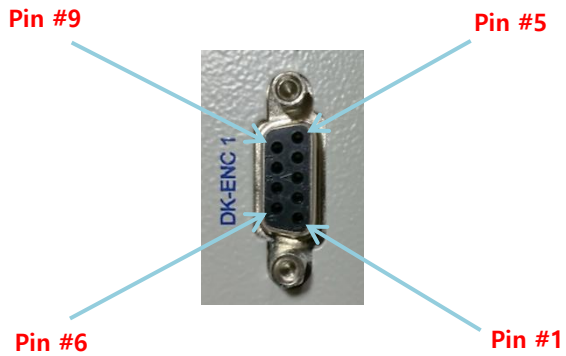

- **Pin Assignment**

OACIS DSUB 9PIN	
Pin #	Description
1	+Vcc (5V)
2	0V
3	A
4	/A
5	B
6	/B
7	Z
8	/Z
9	Shield

C. Encoder Input Port (TTL, Open Collector)

- Compliant with MAGESCALE (SONY) DG Series
- Port Type: DSUB 15pin Female Connector

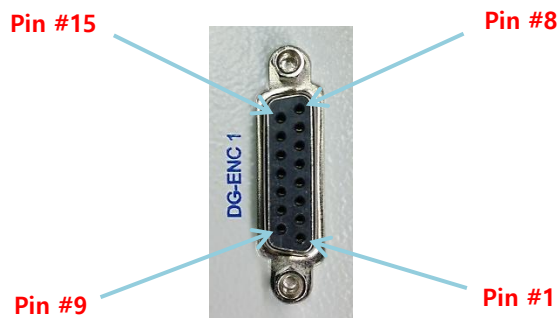

- Pin Assignment

PIN No.	PIN ASSIGNMENT
1	+5V
2	-5V
3	GND
4	/A
5	/B
6	/RESET
7	/Z
8	/ALM
9	GND
10	GND
11	--
12	--
13	--
14	--
15	Shield

X. ESTOP CIRCUIT

A. ESTOP Circuit Diagram

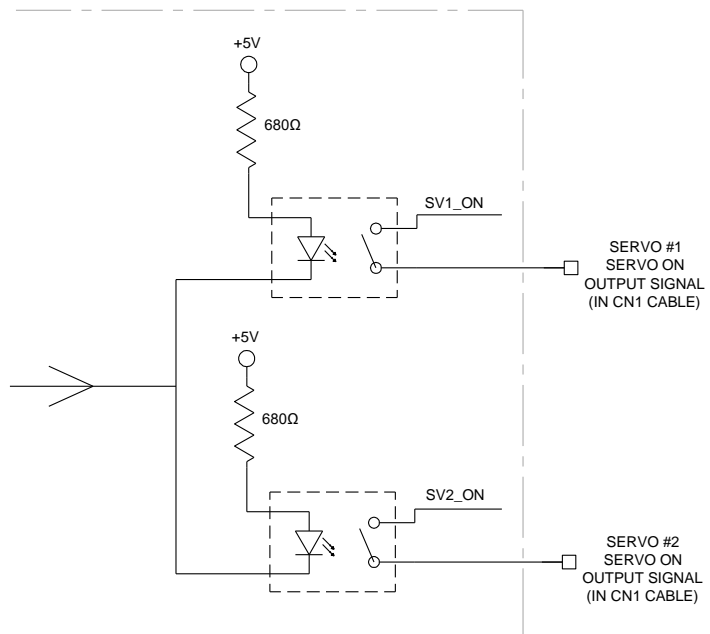
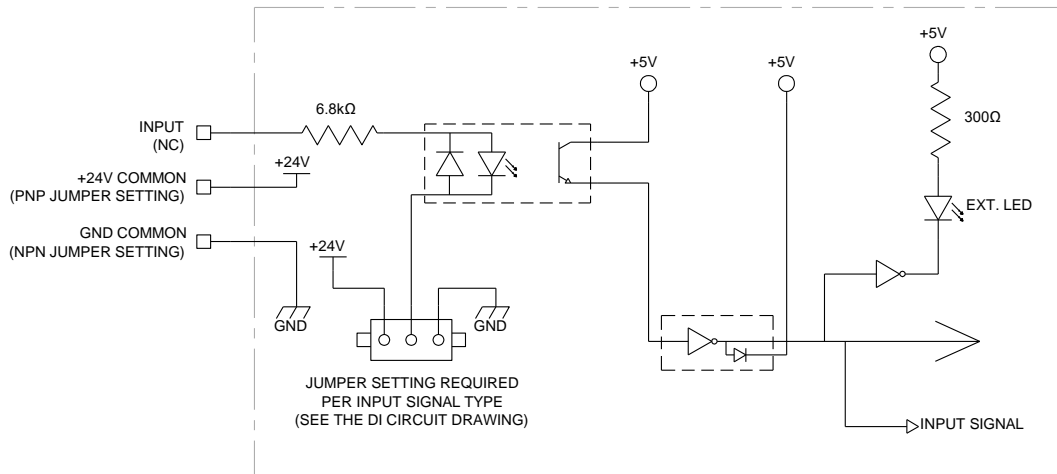

B. Wiring Example

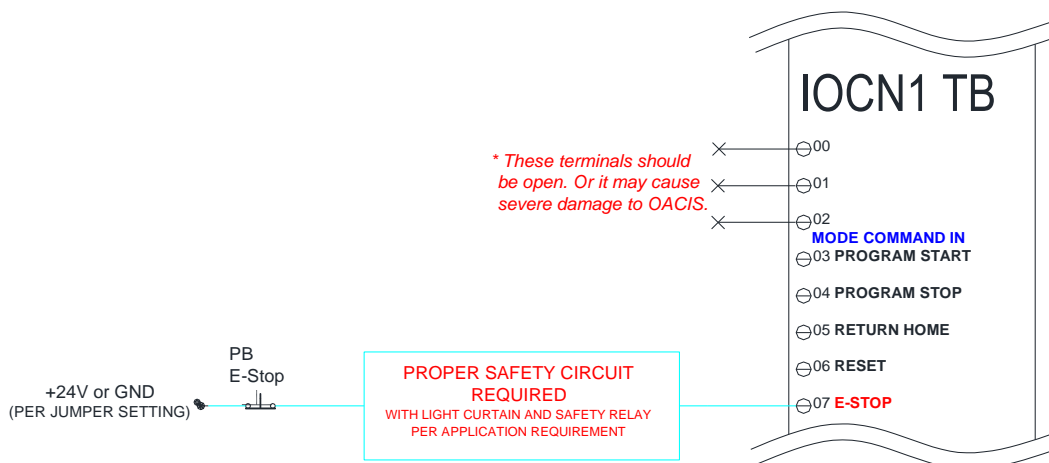

C. Precautions for Wiring

- You need to install the same control relay onto SF1+, SF2+ and E-STOP signal respectively when safety outputs are pulse-type signals and there is no AUX output in the safety relay of STO safety circuit.

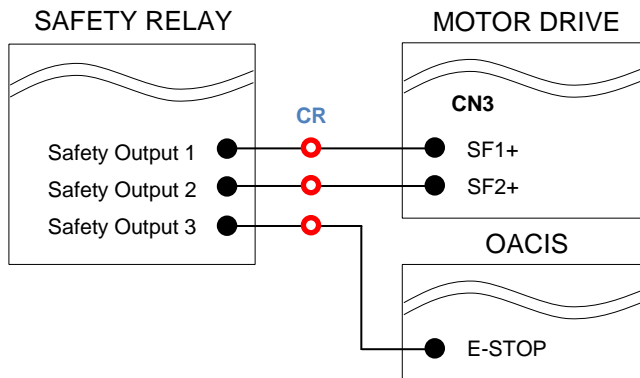

- You need to connect E-STOP to AUX output when safety outputs are pulse-type signals and there is an AUX output in the safety relay of STO safety circuit.

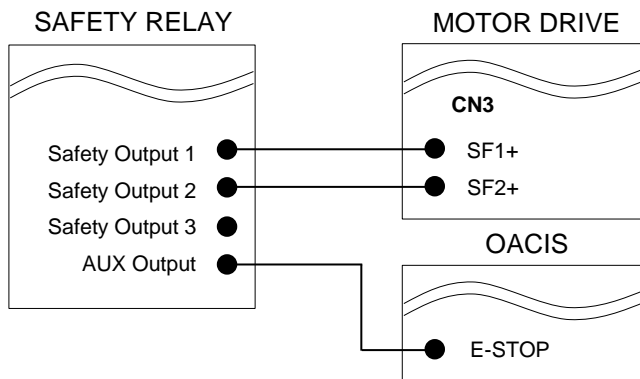

INSTALLATION AND MAINTENANCE INSTRUCTION

XI. POWER DISSIPATION SPECIFICATIONS

A. OACIS-1X : 10 W

B. PANASONIC A5 MOTOR DRIVERS

Servo Presses

Motor Model	Drive			
	Model	Input Voltage, V	Power Output, kW	Power Dissipation, W
MSMD022G1	MADHT1507	220	0.2	33
MSMD042G1	MBDHT2510	220	0.4	36
MSME102G1	MDDHT5540	220	1.0	55
MSME202G1	MEDHT7364	220	2.0	116
MSME302G1	MEDHTA390	220	3.0	218
MSME402G1	MFDHTB3A2	220	4.0	214
MSME502G1	MFDHTB3A2	220	5.0	340
MSME104G1	MDDHT3420	380	1.0	55
MSME204G1	MEDHT4430	380	2.0	74
MSME304G1	MFDHT5440	380	3.0	120
MSME404G1	MFDHTA464	380	4.0	138
MSME504G1	MFDHTA464	380	5.0	212

Nut Runners

Motor Model	Drive			
	Model	Input Voltage, V	Power Output, kW	Power Dissipation, W
MSMD012G1S	MADHT1505	220	0.1	26
MSMD022G1S	MADHT1507	220	0.2	33
MSMD042G1S	MBDHT2510	220	0.4	36
MSMD082G1S	MCDHT3520	220	0.75	39

REVISION

v01.00: Engineering Released

v01.01: Main Board Pictures Revised

v01.02: Hardware Pictures Updated

v01.03: All Damaged Images Revised

v01.04: Wiring Comments Added in VII

v01.05: All Contents Downsized

v01.06:

- Analog Input GND wirings in VI Updated

- Ferrite Wiring in VII Added

v01.07: Power Dissipation Specifications in XI Added

v01.08: Servo Connection Image in VII Revised

v01.09: Mistyping Modified

v01.10: Page Format Updated

v01.11: NPN-related comments in IV.B Added

v01.12:

- Duplicated content deleted in IX.B and IX.C

- Wiring example for external regenerative resistors Added in VII

v01.13:

- Precautions for wiring added in XI.C